

ALL SIZES SHOWN ARE APPROXIMATE ONLY
CAPACITY = 30 LITRES
DRY WEIGHT = 4.5 kg
MATERIAL = POLYETHYLENE
COLOUR = BLACK
WALL THICKNESS = 6mm Min.

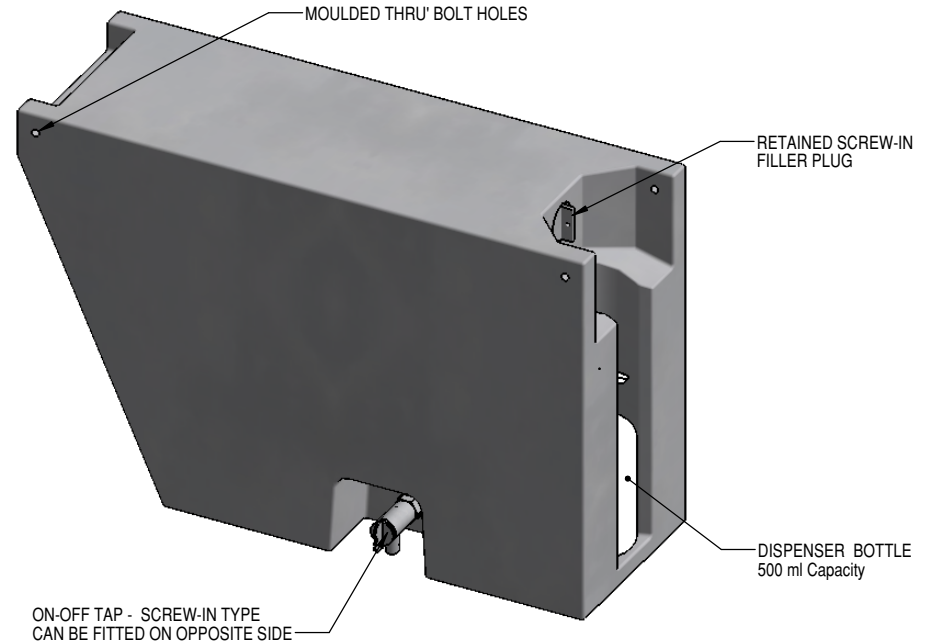
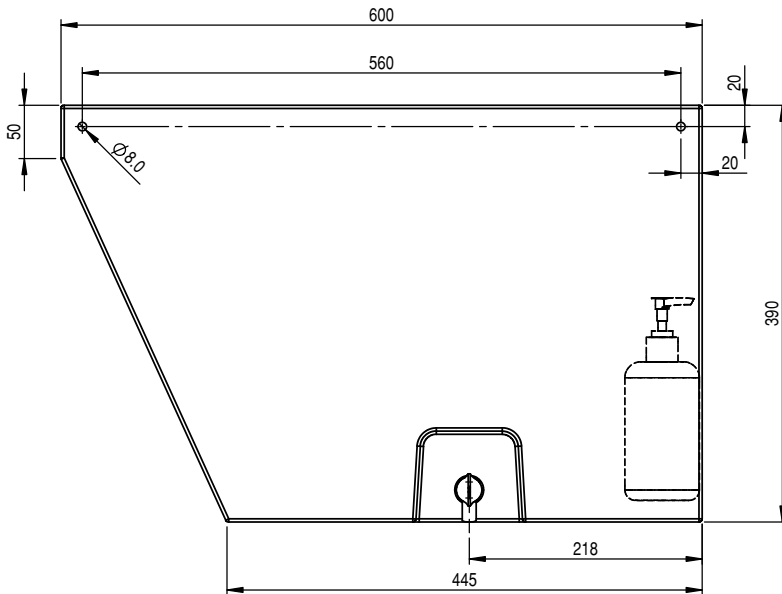
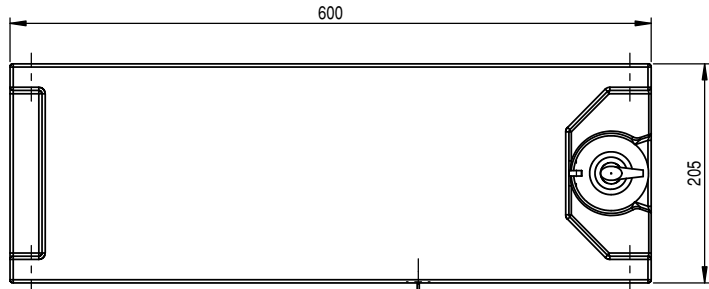

ISOMETRIC VIEW

References:-

COPYRIGHT AND REPRODUCTION

Copyright in the drawings information and data recorded hereon and their format and presentation ("data") is the property of 3D CADWORKS and may not be used, copied or reproduced in whole or part for any purpose other than that for which it is supplied by 3D CADWORKS without the prior consent of 3D CADWORKS. 3D CADWORKS is not responsible for any document or part of a document produced containing data unless that document or the relevant part is identical to the document provided herewith ("the accompanying document"). The terms printed on this label are part of the data and the accompanying documents and must be contained or affixed to any reproduction of the data or the accompanying documents.

Sheet Size

A3

AS 1100-1993



THIRD ANGLE PROJECTION

Client: TOOWOOMBA PLASTICS & SHEETMETAL
 Project: 30 ltr Under-Tray Slim Tank
 Title: 30 Ltr UNDER TRAY SLIM
 GENERAL ARRANGEMENT

Date: 02-03-07
 Scale: 1 : 5
 Drawn By: B Fowler
 Designed By: TP&S
 Checked By: -



3D Cadworks E-Mail - bruce@3dcadworks.com
 8 Daranlee Court PHONE (07) 4638 0281
 Toowoomba Qld 4350 Fax (07) 4638 0281

Drawing No. **07005-001-S1-01~CPT~** Rev.

Call File: D:\Clients\Trmba Plastics\07-005\07005-005-S1-CPT-01

REV.	DESCRIPTION	DATE	APPROVED
REVISIONS			
1			
2			
3			
4			
5			
6			